

BRANT RADIANT

**RE-VERBER-RAY**



HEATERS LIMITED

COMMERCIAL & INDUSTRIAL

SERIES

○ HL3

● DX3

# DX3 SERIES

GAS-FIRED, SINGLE STAGE, INFRARED HEATERS

Packed with quality features, the DX3 represents the highest in quality, single stage, low intensity tube heaters. Performance is enhanced through the use of a specially designed stainless steel burner and black coated titanium stabilized and/or aluminized coated steel radiant tube exchangers. The DX3 Series offers superior low intensity heat, performance and longevity.

## PRODUCT FEATURES

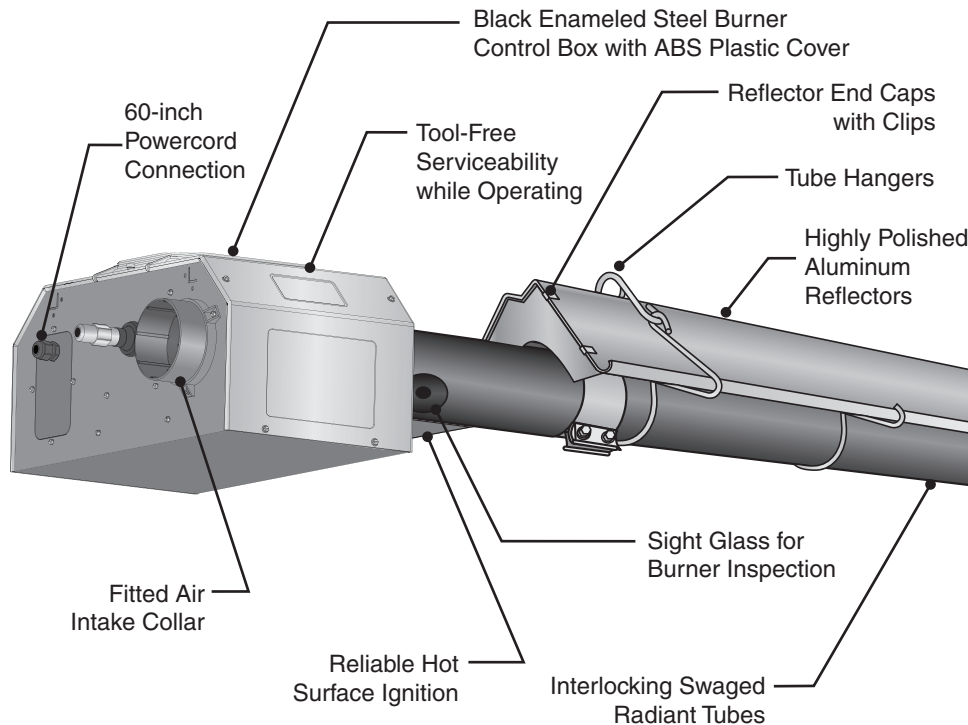

## SPECIFIC FEATURES



- Tool-free access to controls.
- Serviceability while unit is operating.
- Separated air and gas burner chamber.
- Symmetrical placement of ignition tube.
- Hinged control compartment provides ease in servicing.
- 3-piece independent compartment cover.
- ABS plastic air intake collar for connection to 4" PVC/DWV pipe.

### PRODUCT FEATURES COMPARISON CHART

	HL3	DX3
Highly Polished Aluminum Reflectors	•	●
Coated Titanium or Aluminized Combustion Chamber	•	●
Coated Aluminized Radiant Tubes	•	●
Hot Surface Ignition	•	●
Type 1 Rubber Flexible Gas Connector	•	●
Two-stage Technology	•	
Interlocking Swaged Tubes	•	●
Stainless Steel Models Available*	•	●
Reflector End Caps Included	•	●
Optional 'U' or 'L' Configurations Available	•	●

\* Select upgrades available; full stainless models are available in the HL2 and DX2 Series offering.

### BRANT RADIANT HEATERS LTD.

34 Scott Ave.  
Paris, ON N3L 3R1

Phone: 1-519-442-7823  
Toll Free: 1-800-387-4778  
Fax: 1-519-442-7321  
E-mail: sales@brantradiant.com  
Website: www.brantradiant.com

### VISIT OUR WEBSITE FOR:

- Product Specs
- C.A.D. Library
- Parts Support
- Design Guidelines
- Dealer Locator
- Theory of Infrared
- Applications
- and More!

# DX3 SERIES



## SPECIFICATIONS

### PRODUCT SPECIFICATIONS

<b>BTU Range:</b>	50,000-200,000 BTU/h
<b>Lengths:</b>	20-80 Ft.
<b>Gas Type:</b>	Natural or Propane
<b>Combustion Chamber:</b>	Titanium Stabilized or Aluminized Steel
<b>Radiant Tubes:</b>	Coated Aluminized
<b>Certification:</b>	CSA
<b>Limited Warranty:</b>	1-5-10 (Components-Tubes-Burner)

### OPTIONAL EQUIPMENT

<b>"U", "L" or "45°" Configurations:</b>	Available (RUP, REP)
<b>Stainless Steel Upgrades:</b>	Available (SSTRAO)
<b>24V Controls:</b>	Available (24VAO)
<b>Indicator Lights:</b>	Standard
<b>Protective Guards:</b>	Available (PG)
<b>Side Shield Extensions:</b>	Available (SSE)
<b>Outdoor Approval:</b>	Available (OD-KIT)

### ELECTRICAL

- 120V, 60Hz, 3-wire
- 4.8A starting, 1.1A running

### CONTROLS

- Pre-purge
- Potted circuitry
- 120V thermostat control

### TUBE CONSTRUCTION

- As shown at left
- 4" x 10' 16 ga. construction
- Labour saving, interlocking swaged tube design

### REFLECTORS

- Highly polished aluminum
- End caps included
- 0° - 45° rotatable angle
- Reflector tension springs

### IGNITION/SENSE

- Hot surface ignition
- Flame rod sense

### VENTING

- 4" single vent
- 6" common vent with single thermostat
- SK caps on 200 MBH models

### GAS CONNECTION

- ½" or ¾" Type 1 Hose provided

### GAS PRESSURES

- MAN: 3.5" NAT or 10.0" LP
- MIN: 5.0" NAT or 11.0" LP
- MAX: 14.0" NAT or 14.0" LP

### COMBUSTION AIR

- Equipped for ducted air intake from roof or sidewall

### KIT CONTENTS

- All hangers & couplers
- Reflector end caps
- Turbulator baffle(s)

## AVAILABLE DX3 MODELS & CLEARANCES

MODEL #	GAS*	INPUT BTU/h	LENGTH	WEIGHT	MOUNTING HEIGHTS**
DX3-20-50	N or LP	50,000	21'-9"	120 lbs.	9' to 14'
DX3-20-60	N or LP	60,000	21'-9"	120 lbs.	10' to 15'
DX3-20-75 <sup>^</sup>	N or LP	75,000	21'-9"	120 lbs.	11' to 18'
DX3-30-50	N or LP	50,000	31'-5"	160 lbs.	10' to 15'
DX3-30-60	N or LP	60,000	31'-5"	160 lbs.	11' to 18'
DX3-30-75 <sup>^</sup>	N or LP	75,000	31'-5"	160 lbs.	12' to 20'
DX3-30-100 <sup>^</sup>	N or LP	100,000	31'-5"	160 lbs.	13' to 23'
DX3-30-125 <sup>^</sup>	N or LP	125,000	31'-5"	160 lbs.	14' to 25'
DX3-40-50	N or LP	50,000	41'-1"	190 lbs.	11' to 18'
DX3-40-60	N or LP	60,000	41'-1"	190 lbs.	11' to 18'
DX3-40-75 <sup>^</sup>	N or LP	75,000	41'-1"	190 lbs.	12' to 20'
DX3-40-100 <sup>^</sup>	N or LP	100,000	41'-1"	190 lbs.	13' to 23'
DX3-40-125 <sup>^</sup>	N or LP	125,000	41'-1"	190 lbs.	14' to 25'
DX3-40-150 <sup>^</sup>	N or LP	150,000	41'-1"	190 lbs.	15' to 27'
DX3-40-175	N or LP	175,000	41'-1"	190 lbs.	15' to 27'
DX3-50-100 <sup>^</sup>	N or LP	100,000	50'-9"	235 lbs.	15' to 27'
DX3-50-125 <sup>^</sup>	N or LP	125,000	50'-9"	235 lbs.	15' to 27'
DX3-50-150 <sup>^</sup>	N or LP	150,000	50'-9"	235 lbs.	16' to 30'
DX3-50-175	N or LP	175,000	50'-9"	235 lbs.	17' to 35'
DX3-50-200	N or LP	200,000	50'-9"	235 lbs.	18' to 40'
DX3-60-125	N or LP	125,000	60'-5"	265 lbs.	16' to 30'
DX3-60-150 <sup>^</sup>	N or LP	150,000	60'-5"	265 lbs.	17' to 35'
DX3-60-175	N or LP	175,000	60'-5"	265 lbs.	17' to 35'
DX3-60-200	N or LP	200,000	60'-5"	265 lbs.	18' to 40'
DX3-70-175	N or LP	175,000	70'-1"	300 lbs.	19' to 42'
DX3-70-200	N or LP	200,000	70' - 1"	300 lbs.	19' to 42'
DX3-80-200	N or LP	200,000	79'-9"	330 lbs.	20' to 45'

\* Specify natural (N) or propane (LP) gas. \*\* Factory recommended mounting heights are provided as a guideline. Actual conditions may dictate variations from the above data.

<sup>^</sup> Stainless steel tube upgrades available.

### DX3 CLEARANCES TO COMBUSTIBLES (IN.)

MODEL NO.	MOUNTING ANGLE	SIDE		TOP	BELOW	
		FRONT	BEHIND			
DX3-(20,30,40)-50,60	0°	9	9	6	47	
	45°	39	8	10	47	
	W/1 side shield	0°	29	8	6	47
W/2 side shields	0°	9	9	6	47	
	20 ft. from burner	0°	7	7	6	30
	DX3-(20,30,40)-75	0°	9	9	6	60
45°		39	8	10	60	
W/1 side shield		0°	29	8	6	60
W/2 side shields	0°	9	9	6	60	
	20 ft. from burner	0°	7	7	6	30
	DX3-(30,40,50)-100	0°	14	14	6	66
45°		39	8	10	66	
W/1 side shield		0°	29	8	6	66
W/2 side shields	0°	16	16	6	66	
	20 ft. from burner	0°	7	7	6	30
	DX3-(30,40,50,60)-125	0°	20	20	6	76
45°		58	8	10	76	
W/1 side shield		0°	42	8	6	76
W/2 side shields	0°	20	20	6	76	
	20 ft. from burner	0°	7	7	6	30
	DX3-(40,50,60)-150	0°	24	24	6	81
45°		58	8	10	81	
W/1 side shield		0°	42	8	6	81
W/2 side shields	0°	23	23	6	81	
	20 ft. from burner	0°	11	11	6	44
	DX3-(40,50,60,70)-175	0°	34	34	6	92
45°		63	8	10	92	
W/1 side shield		0°	50	8	6	92
W/2 side shields	0°	30	30	6	92	
	20 ft. from burner	0°	11	11	6	44
	DX3-(50,60,70,80)-200	0°	41	41	6	94
45°		63	8	10	94	
W/1 side shield		0°	54	8	6	94
W/2 side shields	0°	30	30	6	94	
	20 ft. from burner	0°	11	11	6	44

Always maintain the published clearances to combustibles.

Clearances published in DX3 Series manual and on warning label supersede data shown on this brochure.

0° Mounting Angle    45° Mounting Angle    0° W/ 1 Side Shield    0° W/ 2 Side Shields

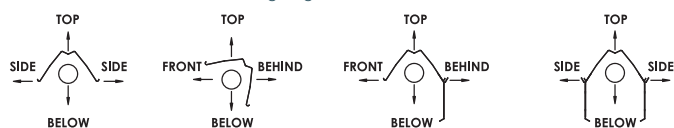

DISTRIBUTED BY:

